

STAGE LEFT

STAGE RIGHT

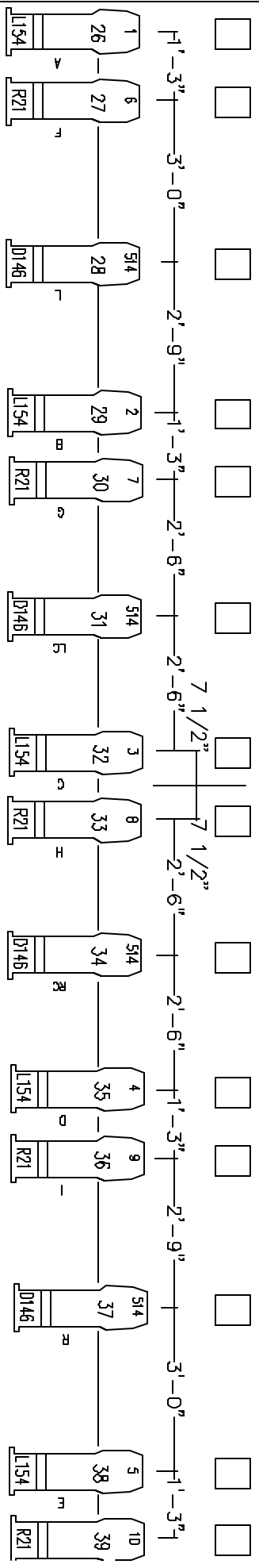

Notes:
 *Need 12 dimmable circuits.
 *Fill in house dimmer number in boxes provided.

NOTE:
 IN DC ONLY – USE 10 DEGREE WITH IRIS UNITS.
 IF D146 IN 10 DEGREE SIZE IS UNAVAILABLE
 REVERT TO STANDARD UNITS.
ORANGE MARKINGS

SYMBOLS

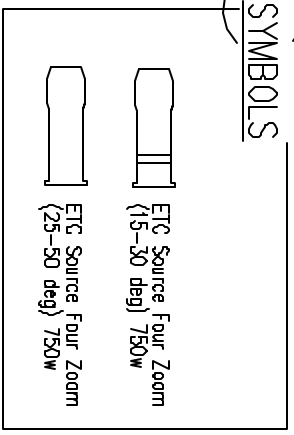

LEGEND

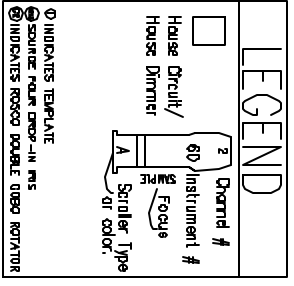

Position should be 40 degrees from stage floor.

COVE

NOT TO SCALE

AIDA – 1st NATIONAL TOUR
 Lighting Designer: Natasha Katz
 Associate LD: Edward Pierce
 Production Electrician: Robert Fehrbach
 Head Electrician: Eric Rimes (312-953-0813 cell)